

TestMate® Water Sensor (TWS-C)

Description

The TWS-C is a water and temperature sensor for the continuous monitoring of hydraulic and lubrication fluids - accurately, continuously and on line. It measures the water content relative to the saturation concentration (saturation point) and outputs the degree of saturation (saturation level) in the range of 0 to 100% as a 4-20 mA signal. A reading of 0% would indicate the absence of water, while a reading of 100% would indicate that a fluid is saturated with water.

The special capacitance sensor used in the TWS absorbs water molecules from the fluid and changes its capacity value that is directly related to the saturation level in the fluid. An integrated thermoelement on the sensor measures the temperature of the fluid in the range of -13 to 212 F (-25 to 100°C) and outputs it as a 4 to 20 mA signal.



Installation

The TWS-C can be directly installed into the hydraulic system with the threaded connection. The recommended mounting position is vertical with the mechanical connection pointing upwards in hydraulic applications. During installation, attention must be paid concerning a suitable place of mounting in order to have the sensor fully submerged and fluid free-flowing around the sensor. That is why during tank installation only those places should be chosen where there is well known turbulence.

The electrical connection should be carried out by a qualified electrician according to the relevant regulations of the country concerned. The TWS-C carries the CE mark. A declaration of conformity is available on request. The relevant EMC standards are: EN 61000-6-1; EN 61000-6-2, EN 61000-6-3, EN 6100-6-4.

The requirements of the standards are fulfilled only if the sensor housing is grounded correctly by qualified personnel. When installing the TWS-C into a hydraulic block, it is sufficient if the block is grounded via the hydraulic system.

Adherence to the following recommendations will reduce the effect of electromagnetic interference:

- Make inline connections as short as possible.
- Use screened cables (e.g. LIYCY 4x0.5 mm²).
- The cable screening must be fitted by qualified personnel subject to the ambient conditions and with the aim of suppressing interference.
- Direct proximity to connecting lines of user units or electrical or electronic units causing interference must be avoided as much as possible.



Functionality

What is the desired saturation level in hydraulic and lubrication systems?

Since the effects of free (also emulsified) water is more harmful than those of dissolved water, water levels should remain well below the saturation point. However, even water in solution can cause damage and therefore every reasonable effort should be made to keep saturation levels as low as possible. There is no such thing as too little water. As a guideline, we recommend maintaining saturation levels below 45% in all equipment.

The TWS-C is individually calibrated on computer-controlled test rigs and subjected to a final test and should operate perfectly when used according to the specifications (see Section 9, Technical Data).

If you have any questions regarding technical details or the suitability of the TWS-C for your application, please contact our sales/technical department. Interference by anyone other than Schroeder personnel will invalidate all warranty claims.

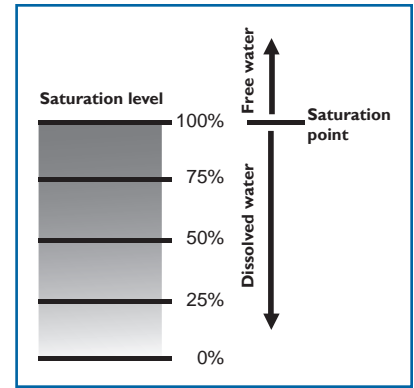

Dimensions

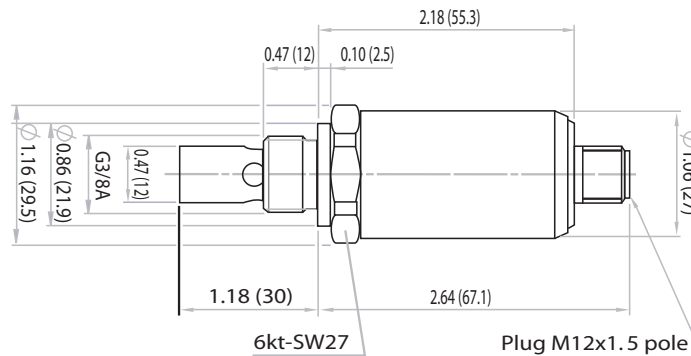

* Metric dimensions in ()

Circuit Diagram

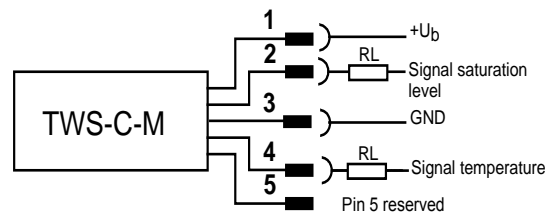

$$R_{Lmax} = (U_B - 10 \text{ V}) / 20 \text{ mA [k}\Omega\text{]}$$

$$R_{Lmin} = 47 \Omega$$



Model Code

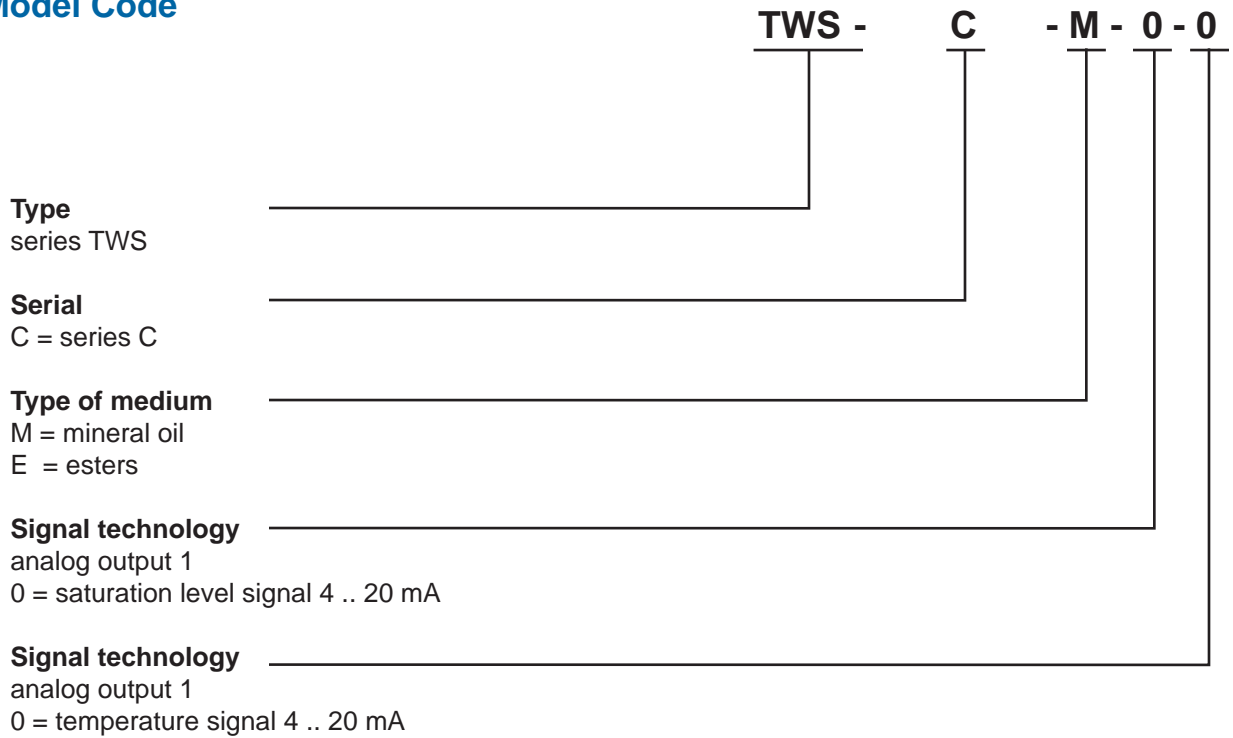

Included In Delivery

Sensor
Manual

Accessories

ZBE 08 (5 pole)
Connector M12x1, right-angled

ZBE 08-02 (5 pole) with 2m cable

ZBE 08-05 (5 pole) with 5m cable

ZBE 08S-02 (5 pole) with 2m screened cable

ZBE 08S-05 (5 pole) with 5m screened cable

ZBE 08S-10 (5 pole) with 10m screened cable

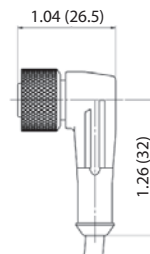
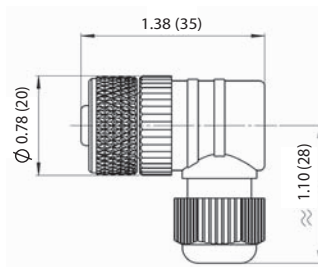

Color Code

Pin 1: Brown
Pin 2: White
Pin 3: Blue
Pin 4: Black
Pin 5: Grey



Technical Data

INPUT DATA	
Measuring range (saturation level)	0 ... 100 %
Measuring range (temperature)	-13 ... 212 F / 25 .. +100 °C
Operating pressure	Max. 725 psi, / max. 50 bar
Overload pressure	Max. 9135 psi / max. 630 bar
Parts in contact with media	stainless steel, seal viton or EPDM, ceramic with evaporated metal
OUTPUT DATA	
<i>Humidity measurement</i>	
Output signal (saturation level)	4 .. 20 mA
Calibrated accuracy	≤ ± 2 % FS max.
Accuracy in media measurements	≤ ± 3 % FS typ.
Pressure-dependent	+ 0.02 % FS/bar
OUTPUT DATA	
<i>Temperature measurement</i>	
Output signal (temperature)	4 .. 20 mA
Accuracy	* ± 2% FS max.
AMBIENT CONDITIONS	
Nominal temperature range (saturation level measuring)	32 ... 194 F / 0 .. +90 °C
Ambient temperature range	-40 ... 212 F / -40 .. +100 °C
Fluid temperature range	-40 ... 257 F -40 .. +125 °C
Viscosity range	32 .. 23175 SUS
Flow velocity	< 16 ft/s
Media tolerance	mineral oil based fluids, natural and synthetic esters
CE mark	EN 50081-1, EN 50081-2 EN 50082-1, EN 61000-6-2
Type of Protection acc. DIN 40050	IP 67
OTHER DATA	
Supply voltage	12 .. 32 V DC
Residual ripple supply voltage	≤ 5 %
Mechanical connection	G3/8A DIN 3852
Torque rating	18.5 ft-lbs.
Electrical connection Pin 1: +Ub Pin 2: Signal saturation level Pin 3: 0V / GND Pin 4: Signal temperature Pin 5: not connected	M12x1, 5 pole (DIN VDE 0627)
Reverse polarity protection of the supply voltage, excess voltage, override and short circuit protection	standard

FS (Full Scale): relative to the full measuring range



580 West Park Road • Leetsdale, PA 15056
p. 724.318.1100 • f. 724.318.1200

An ISO 9001: 2008 Certified Company

www.schroederindustries.com