



ColdClear™

BCC900 Series

New!

Cold Weather. Clear Biodiesel. The Clear Solution.

The new ASTM D6751 Cold Soak Filtration test is leaving many biodiesel producers and consumers “out in the cold”. In response, Schroeder Biofuels is proud to present ColdClear™, a new proprietary, patent pending, multi-stage separation technology designed specifically to ensure that biodiesel products conform to this ASTM standard for cold flow properties. The ColdClear™ system consists of a three-stage bank of housings using a combination of filtration and adsorption principles to capture compounds that could cause plugging or crystallization in biodiesel fluids. Notably, ColdClear™ is the premiere multi-stage treatment system for solving the cold soak filtration dilemma in B100 biodiesel and biodiesel blends in a single pass while resulting in a negligible yield loss.



- ColdClear™ is a three stage system with all housings mounted in series on a single skid
- The first stage serves as a pre-filter and captures solid particulates down to three microns using high efficiency Excellement® cartridges
- Stages 2 and 3 utilize cartridges that combine adsorption technologies with the proven effectiveness of Schroeder's high efficiency Excellement® synthetic media
- The standard ColdClear™ system is equipped with either 3" NPT or 3" ANSI 150# flange ports and is designed to handle a maximum flow of 45 gpm for an estimated 120,000 gallons
- Multiple units can be employed to meet higher flow requirements
- The ColdClear™ system can be easily integrated into existing plant piping environments
- If multiple units are required, Schroeder Biofuels offers a range of flow & system monitoring options to ensure proper operation
- The essence of the ColdClear™ technology is the removal of crystallization precursors from the biodiesel or biodiesel blends. Therefore knowing the exact flow rate of your system is essential for the ColdClear™ system to be properly sized and configured for a specific application.

Specifications

Flow: Up to 45 gal/min (170 L/min)

Max Operating Pressure: 150 psi (10.3 bar)

Operating Temperature: 70°F optimal (40°F to 100°F)

Pod Construction: Steel

Cartridge Type: BCC39QPRE & BCC39QPOL

Element Change Clearance: 39" (990.6 mm)

ColdClear™ is only available through the Schroeder Biofuels network of authorized distributors and representatives.

SchroederBIOfuels
Filtration Solutions for Renewable Energy Sources

580 West Park Road • Leetsdale, PA 15056
p. 724.318.1100 • f. 724.318.1200

Typical Applications

- In-plant treatment of biodiesel (B100) conform to ASTM standards prior to blending or shipment
- In-plant treatment of biodiesel blends (ex. B5, B10, etc) to ensure blended biodiesel meets or exceeds cold flow specifications
- For use in diesel fuel storage and distribution systems where B100 or biodiesel blends are stored and distributed to ensure shipped blends conform to ASTM specifications
- Large fleet terminals that have on-site diesel (and biodiesel blend) storage to ensure tight adherence to cold flow standards
- Pre-treatment of fats and oils prior to processing

Ordering Information

How to Build a Valid Model number for a Schroeder BCC900:

BOX 1	BOX 2	BOX 3	BOX 4	BOX 5	BOX 6
BCC900					

Example: NOTE: One option per box

BOX 1	BOX 2	BOX 3	BOX 4	BOX 5	BOX 6	
BCC900	V	P48	P48	D5	UU	= BCC900VP48P48RD5UU

BOX 1	BOX 2	BOX 3	BOX 4	BOX 5	BOX 6
Model Code	Seals	Inlet Porting	Outlet Porting	Stage 1 Indicator	Test Points
BCC900	V = Viton	P48 = 3" NPT A48 = 3" ANSI 150# Flange	P48 = 3" NPT A48 = 3" ANSI 150# Flange	Omit = None RD5 = Visual Pop-up DPG1 = Differential pressure gauge RMS10 = Electrical w/ DIN connector (male end only)	Omit = None UU = Test points in each stage

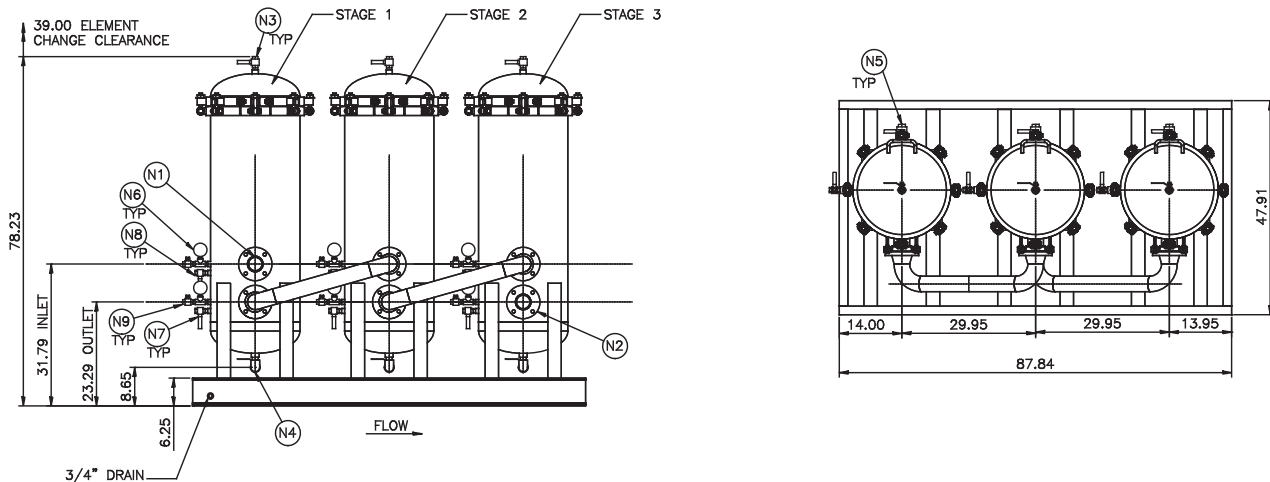

Replacement Cartridges

Stage 1 Cartridge	BCC39QPRE
Stage 2 & 3 Cartridges	BCC39QPOL